



SILK WAY 2021 RALLY 丝绸之路拉力赛



**MORE THAN RALLY
ABSOLUTE ADVENTURE**



**PRESS
REGULATIONS**

www.silkwayrally.com





SUMMARY

| | |
|---------------------------------------------------------------------------------------|-----------|
| GENERAL CONDITIONS | 3 |
| TYPES OF PRESS ACCREDITATIONS | 3 |
| PRESS ROOMS..... | 4 |
| AVAILABLE INFORMATION | 4 |
| TRANSMISSIONS AT THE BIVOUACS..... | 4 |
| ACCOMMODATION AND CATERING..... | 4 |
| DRIVER'S CODE GENERAL | 5 |
| ASSISTANCE/ SERVICE TO A COMPETITOR | 5 |
| TRAFFIC/ SPEED | 5 |
| MAXIMUM SPEED..... | 6 |
| SPEED CONTROL ZONES | 7 |
| BIVOUAC/ TOWN SPEED LIMIT..... | 8 |
| ALCOHOL DRIVING: NO TOLERANCE AT ALL!!..... | 8 |
| NON-COMPLIANCE WITH REGULATIONS | 8 |
| INDIVIDUAL PRESS CAR PACK | 9 |
| PRESS VEHICLES | 11 |
| IDENTIFICATION..... | 11 |
| ITINERARY | 12 |
| ROAD BOOKS AND INSTRUMENTS | 12 |
| IDENTIFICATION AND MARKINGS..... | 13 |
| TECHNICAL REGULATIONS FOR PRESS VEHICLES FOLLOWING THE RACE ROUTE | 14 |
| SAFETY EQUIPMENT FOR PRESS CARS FOLLOWING THE RACE ROUTE..... | 14 |
| ROLL BARS | 15 |
| SENTINEL GPS SYSTEM (race route only) | 15 |
| PERSONAL SAFETY | 15 |
| SAFETY EQUIPMENT FOR PRESS CARS FOLLOWING THE SERVICE ROUTE | 15 |
| FUEL..... | 16 |
| TRACK CLOSURE..... | 16 |
| LOSS OF VEHICLE | 17 |
| RESPECT SENSITIVE AREAS | 17 |
| PRESS ACCREDITATION PLANE/ BUS | 18 |
| LUGGAGE..... | 19 |
| TRANSPORT | 20 |
| PRESS ACCREDITATION SERVICE VEHICLE | 21 |
| ASSISTANCE/SERVICE TO A COMPETITOR | 22 |
| PRESS ACCREDITATION HOSTED MEDIA..... | 23 |
| DAILY PRESS ACCREDITATION | 25 |
| FINAL PROVISIONS..... | 26 |
| CONTACTS..... | 26 |
| APPENDICES..... | 27 |
| APPENDIX 1: RULES OF CONDUCT AND OBLIGATION OF THE JOURNALIST | 28 |
| APPENDIX 2. SAMPLE LETTER OF THE EDITOR-IN-CHIEF | 30 |
| APPENDIX 3: SAMPLE APPLICATION FOR HOSTED MEDIA ACCREDITATION | 31 |
| APPENDIX 4: TECHNICAL REQUIREMENTS FOR VIDEOS SENT FROM THE MEDIA CENTER | 32 |
| APPENDIX 5: LIMITED IMAGE LICENSE. RULES OF USAGE FOR IMAGES AND VIDEOS | 33 |



GENERAL CONDITIONS

Dates of the event: from 01 to 11 July 2021.

Regions and counties: Russia and Mongolia

Accreditation start at: 15th of April, 2021.

Administrative checks and scrutineering: Omsk (Russia), 30 June - 01 July 2021.

Finish: Ulaanbaatar, July 11

Only the English version of these current regulations is binding. Russian, French and Chinese translations are also available.

Attention: Rally timetable will be available later. It will be formed in accordance with the COVID-19 Mitigation plan of the Silk Way Rally

TYPES OF PRESS ACCREDITATIONS

| Permanent accreditation from 01 to 11 July, 2021 | | | | «DAILY ACCREDITATION» |
|-----------------------------------------------------------|------------------------------------------------------------------------------------------------|------------------------------------------------|--------------------------------------------------|--------------------------------------------------------|
| INDIVIDUAL PRESS CAR PACK | INDIVIDUAL PRESS ACCREDITATION PLANE / BUS | INDIVIDUAL PRESS ACCREDITATION SERVICE VEHICLE | ACCREDITATION HOSTED MEDIA | |
| Private car is used (not supplied by the race Organizers) | Movement from Omsk to the city of finish by plane and by bus, chartered by the race Organizers | Own transport | Applications are accepted on a competitive basis | Accessible for visit: three rally stages (days) |
| Use of media center and Internet | | | | X |
| Catering at the rally bivouacs on the route | | | | X |
| 3200 € | 5300 € | 3200€ | FREE | FREE |
| Accreditation finish: 01 June 2021 | | | 14 May 2021 | Two days before the visit |

THE NUMBER OF ACCREDITATIONS IN CATEGORIES ARE LIMITED.

The permanent accreditations are valid for the whole rally. No change of name will be possible during the rally. The organizing committee reserves the right to accept or refuse any request for accreditation.



PRESS ROOMS

Fully equipped press rooms: tables, chairs, lights, electrical plugs, internet wired connections, etc. will be available only for **PERMANENT** accredited journalists at all bivouacs on the rally route.

Media center opening hours: daily from the moment of opening until 10 p.m.

AVAILABLE INFORMATION

All press information will be available and released by the media center in Russian, French, English and Chinese:

- race news, live text,
- competitors' positioning during the special stages,
- classifications by the stage results,
- press releases,
- interviews,
- pictures,
- videos.

Information will be posted on boards, on screens, as well as on the event official website www.silkwayrally.ru.

TRANSMISSIONS AT THE BIVOUACS

A Wi-Fi system will be available at the press center. Access to Internet (only for **permanent** accredited journalists) will be provided by the Organizers.

The connection information will be issued during administrative checks.

Internet will be available every day until 10 p.m.

The Organizers do not supply computers and printers. All journalists and press officers are expected to provide their own equipment that is desirable to be insured.

ACCOMMODATION AND CATERING

At the bivouac the accredited journalist is provided with the space to pitch a tent and possibility to use showers and toilets.

The overnight at the bivouac is only possible in the individual tents.

Tents are not provided by the Organizers.

Most bivouacs will be located close to cities. Therefore, journalists wishing to stay in hotels will have a possibility to book one by themselves.



Catering at the bivouacs is included in ALL PERMANENT PACKS and will be organized for from 02 to 10 July (breakfast, packed lunch, dinner), on 11 July (breakfast).

Journalists having **DAILY ACCREDITATIONS** are not allowed to benefit from the bivouac's catering.

DRIVER'S CODE GENERAL

All journalists, participants and crews are obliged to behave with respect and courtesy on the route to each other and towards:

- the population of the country,
- the other competitors,
- the Organizers.

They should follow the instructions of the rally Organizers and marshals at the special stages, bivouacs and CP.

Any impoliteness which is proven will be subject to a penalty of €500 or the accreditation cancellation and withdrawal from the race.

ASSISTANCE/ SERVICE TO A COMPETITOR

A person having a press accreditation is not allowed to help the race competitors in whatever manner!

IT IS PROHIBITED:

- to transport spare parts,
- to transport bivouac equipment,
- to help with technical problems, etc.

If such is the case, this person could be expelled from the rally and lead to withdrawal from the race of the concerned competitor.

TRAFFIC/ SPEED

1. Throughout the entire Event, crews must strictly observe the traffic laws, as well as road signs. In the case of the police control infringement, crews will be fully responsible for the facts they have been arrested for. Any fines will be combined with penalties for non-compliance with the speed limits.
2. In Russia and Mongolia all vehicles (racing and assistance) must drive with lights on constantly (special stages and liaisons).
3. Radar controls will be carried out along the itinerary by local police forces.



4. The registration plate must be fixed at the front and at the rear of the vehicle and the number must be legible.
5. All crews not respecting the traffic laws of the countries crossed, driving at an excessive speed or behaving in a dangerous manner may be fined by police and get additional penalties from the Organizers up to exclusion from the race.

MAXIMUM SPEED

1) In addition to the speed control zones (Art. 26P2), the maximum speed will be limited and controlled by the GPS (TRIPY or ERTF) throughout the liaisons (road sections), except in cases detailed in a bulletin and/or in the road book.

The maximum allowed speed is the speed allowed by the **Traffic Laws of the countries being crossed.**

2) In Russia, on roads and outside special stages, speed is limited to:

- **70 kph for trucks,**
- **90 kph for cars.**

In Mongolia, on roads and outside selective sections, speed is limited to:

- **60 kph for trucks,**
- **60 kph for cars.**

If the local speed limit is lower, it applies.

3) When over speeding a sign will appear on the screen of the GPS, together with an audio signal. The GPS will be controlled when entering the bivouacs (the information is automatically transmitted by radio). In the case of infringement, the person carrying out the checks will make a report of violation that must be signed by a crew member.

Any refusal to sign will result in the following penalties:

- 1st refusal: the car will be blocked at the TC (time control point),
- 2nd refusal: penalty, up to exclusion.

4) When over speeding, the GPS records the length of the over speeding, as well as its value. Any over speeding will lead to the following penalties:

- **from 1 to 20 kph:**
 - fine of 100 € for violation between 00 and 500 meters of over speeding;
 - fine of 400 € for violation over 500 meters of over speeding;
- **from 21 to 40 kph:**
 - fine of 600 € for violation between 00 and 500 meters of over speeding;



- fine of 1.000 € for violation over 500 meters of over speeding + exclusion of the vehicle and its crew from the race

- **these penalties come in addition to those imposed for over speeding from 1 to 20 kph.**

- **over 40 kph:**

- fine of 1.000 € minimum + exclusion of the press car and its crew from the race + 5-minute-penalty to the best ranked vehicle of the team (if the press car is part of the team);
- in case of repeated action, including by another vehicle of the same team, there may be a penalty that may go as far as exclusion of the best ranked vehicle of the team.

The fine should be paid within 24 hours after notification, otherwise the crew will be excluded from the race.

SPEED CONTROL ZONES

1) There will be speed control zones on the itinerary, in settlements, on natural roads, etc. They will be indicated on the road book and controlled by the GPS (TRIPY or ERTF).

When crossing these zones, press cars must respect the speed indicated on the road book.

2) Any over speeding in the same zone will be considered as a single violation. Any over speeding in another zone will be considered as the second violation.

3) Any over speeding will lead to the following penalties:

- **from 1 to 20 kph:**

- fine of 100 € for violation between 00 and 200 meters of over speeding;
- fine of 400 € for violation over 200 meters of over speeding;

- **from 21 to 40 kph:**

- fine of 600 € for violation between 00 and 200 meters of over speeding;
- fine of 1.000 € for violation over 200 meters of over speeding + exclusion of the vehicle and its crew

- **these penalties come in addition to those imposed for over speeding from 1 to 20 kph.**

- **over 40 kph:**

- fine of 1.000 € minimum + exclusion of the press car and its crew from the race + 5-minute-penalty to the best ranked vehicle of the team (if the press car is part of the team);



- in case of repeated action, including by another vehicle of the same team, there may be a penalty that may go as far as exclusion of the best ranked vehicle of the team.

The fine should be paid within 24 hours after notification, otherwise the crew will be excluded from the race.

BIVOUAC/ TOWN SPEED LIMIT

It is forbidden to, under risk of penalty up to and including exclusion:

- drive at excessive speed (more than **20km/h**) within the bivouac area,
- drive dangerously in the area of the bivouac or at the stage in town (where local speed limits must be respected),
- drive on airstrips.

Any violation will lead to a penalty up to exclusion from the race.

IMPORTANT

U-turns are forbidden on the race track.

To take pictures, you must park several meters from the track where your car will be seen from a distance and you will not obstruct the passage of the competitors.

ALCOHOL DRIVING: NO TOLERANCE AT ALL!!

The participants settle their problems with the State Traffic Safety Inspectorate of Russian Federation and Traffic police of Mongolia.

It is necessary to take into account that for traffic regulations violation (drunk driving, driving on a lane of oncoming traffic in the places, where it is forbidden, overtaking rules violation, etc.) the Russian and Mongolian legislations provide strict sanctions up to arrest and imprisonment.

NON-COMPLIANCE WITH REGULATIONS

Failure to respect the regulations by any accredited person will automatically lead to his/her exclusion from the event. This could lead to the exclusion of the entire crew (all passengers of the same vehicle).



INDIVIDUAL PRESS CAR PACK

3200 €

per person

Accreditation period: 01-11 July 2021. Entire rally route.

Full payment of the INDIVIDUAL PRESS CAR PACK entry fee must be done right after you receive the confirmation of your accreditation from the Organizers and before 1st June 2021.

Change of name is impossible after 1st June 2021.

Individual press car pack is divided into two categories:

a) Press cars following the race route.

b) Press cars following the assistance route only.

To get the accreditation for the entire rally route the press cars (**not provided by the Organizers**) must compulsorily pass administrative checks and scrutineering according to the rally schedule.

Vehicles not equipped with safety equipment mentioned below will not be allowed to start.

Crew:

- a minimum of two people
- a maximum of four people, **but no more than three people from one media.**

Only five-door 4x4 vehicles will be allowed to transport more than 2 people.

The number of press cars being allowed to enter the race route is limited. The priority will be given to TV cars and photographers.

The organizing committee reserves the right to accept or refuse any request for accreditation.

Organizers cover the following costs:

This accreditation does not include the following:

- | | |
|--------------------------------------------------------------------------------------------------------------------------------------------------------------------------------------------------------------------------------------------------------------------------------------------------------------------------------------------------------------------------------------------------------------------------------------------------------------------------------------------------------------------------------------------------------------------------------------------------------------------------------------------------------------------------------------------------------------------------------------------------------------------------------------------------------------------------------------------------------------|------------------------------------------------------------------------------------------------------------------------------------------------------------------------------------------------------------------------------------------------------------------------------------------------------------------------------------------------------------------------------------------------------------------------------------------------------------------------------------------------------------------|
| <ul style="list-style-type: none"> - Meals at the bivouacs from 02 to 10 July (breakfast, packed lunch, dinner), 11 of July - breakfast - Race and assistance Road Books, media-guide and other documentation. - Data transmission from the media center at the start, finish and from the bivouacs, Internet connection in the press center at the start and finish (traffic limits are fixed by the Organizers). - Participation in the Prize Giving ceremony. - Insurance and medical repatriation. - Rental of the ERTF - GPS UNIK II (compulsory for race route CARS). - Rental of the Iritrack (compulsory for race route cars). - Rental of the smalltrack including device mounts (compulsory for assistance route cars). - Ambulance repatriation insurance. | <ul style="list-style-type: none"> - Flight to the Omsk and from Ulaanbaatar - Accommodation at the start and at the finish. - Meals in Omsk and Ulaanbaatar. - Travel expenses. - General liability insurance. - Fuel. - Vehicle transportation to Omsk and from Ulaanbaatar - Phone calls. - Tent, sleeping bag and other bivouac equipment. - Visa expenses. - Rental of satellite phone (optional). |
|--------------------------------------------------------------------------------------------------------------------------------------------------------------------------------------------------------------------------------------------------------------------------------------------------------------------------------------------------------------------------------------------------------------------------------------------------------------------------------------------------------------------------------------------------------------------------------------------------------------------------------------------------------------------------------------------------------------------------------------------------------------------------------------------------------------------------------------------------------------|------------------------------------------------------------------------------------------------------------------------------------------------------------------------------------------------------------------------------------------------------------------------------------------------------------------------------------------------------------------------------------------------------------------------------------------------------------------------------------------------------------------|

Organizers will accept applications for permanent **INDIVIDUAL PRESS CAR PACK** accreditation sent online via the official rally website www.silkwayrally.com before **01 June, 2021**.

Request for accreditation, sent after this date, will not be accepted.

The INDIVIDUAL PRESS CAR PACK accreditation request form must be completely filled out on the website www.silkwayrally.com and sent to the organizing committee along with the following documents (sent/ attached in electronic form):

- Letter from the editor-in-chief of the media, indicating the purpose of the trip, a preliminary plan of the publications about the rally and media output data (circulation (audience), distribution/ broadcasting area (see sample in Appendix 2)).
- Letter from the sports team head, if the application comes from the team press officer.
- Copy of a press card (editorial card) of accredited journalists/photographers.
- For the press cars drivers with the right to go to the track, confirmation of off-road driving experience (see the Appendix to the “press car” application).
- Obligation to comply with press regulations (see Appendix 1).
- Medical certificate (see the application form on the website www.silkwayrally.ru).
- Color photo 3x4 cm for each crew member. Recent less than 6 months
- Copy (scan) of passport.
- Copy (scan) of driving license.



- Copy of car registration certificate.
- Copy of car insurance documents, which must be valid and operating in the countries crossed (otherwise, a special Insurance mount will be available at administrative checks).
- Authorization from the owner of the vehicle, if the latter is not part of the crew.
- 5 photos of the vehicle entered (see details during online registration at the race website www.silkwayrally.com).

The organizing committee will confirm the permanent **INDIVIDUAL PRESS CAR PACK** accreditation before 5 June, 2021.

Each journalist or photographer benefiting from a permanent **INDIVIDUAL PRESS CAR PACK** accreditation must compulsorily be present at the administrative checks and show the valid documents mentioned above in their original form.

Any original document missing at administrative checks and/or scrutineering will lead to a refusal of accreditation for the journalist/ photographer.

No photocopies or declaration of loss and/or theft will be accepted.

PRESS VEHICLES

Depending on the type of vehicle entered, a press car crew must be made up of a minimum of two people and a maximum of four people.

Only **five-door 4x4s** will be allowed to transport four journalists (it is mandatory to present a vehicle registration certificate).

No changing of passengers will be authorized after 1 June, 2021. If a member of the crew leaves his vehicle as a result of unforeseen circumstances, the vehicle may continue the rally on condition that the Organizers are informed of this and agree.

Press cards are required, except for the car driver, but he is obliged to confirm his experience of participating in cross-country rallies by sending his resume.

IDENTIFICATION

During the scrutineering, identification stickers of different colors will be applied to the press cars.

| GREEN STICKERS | YELLOW STICKERS |
|-----------------------|------------------------|
| Racing route | Assistance route |

All accredited press cars will be parked at the reserved parking at all bivouacs.



ITINERARY

Press vehicles following the race route **(green stickers)** are allowed to drive on the itinerary of their choice: racing or assistance. Every day the code corresponding to the selected itinerary (racing or assistance) must be entered in the GPS.

CAUTION: IN ORDER TO ENTER THE RACE ROUTE, IT IS MANDATORY TO ENTER THE SPECIAL STAGE AT LEAST ONE HOUR BEFORE THE START OF THE FIRST COMPETITOR. CARS WILL NOT BE ALLOWED TO ENTER THE ROUTE AFTER THAT TIME.

Press cars with yellow stickers must drive on the assistance route ONLY. For safety reasons, they must not drive along the racing route in any case, except upon exceptional authorization of the Organizers. Not respecting this rule will lead to the withdrawal of the accreditation (removal of stickers). Thus, the vehicle will not be allowed to enter the bivouacs, and to transport people, accredited for the rally. According to the circumstances of the violation, accreditations of the passengers entered in this vehicle may be withdrawn as well, even if these people were not inside the vehicle during the violation.

ROAD BOOKS AND INSTRUMENTS

Accredited press vehicles may follow the entire rally and will get the following road books: «Assistance» Road Books will be distributed during administrative checks at the start

The race route cars will be briefed on safety during administrative checks, where information on how to obtain photo points will be provided.

If a press vehicle wishes to move ahead on the route, a specific request must be made in the media center and accepted by both press and sporting departments.

GREEN STICKERS

Iritrack will be used as a positioning system. Every day press cars **MUST** allow the control of their GPS (ERTF) at the entrance to the bivouac.

Any refusal to sign will lead to the following penalties:

- 1st refusal: vehicle blocked at TC,
- 2nd refusal: penalty up to and including exclusion.

YELLOW STICKERS



Smalltrack will be used as a location-based tracking device without embedded voice & SMS. Every day press cars MUST allow the control of their GPS at the entrance to the bivouac.

Any refusal to sign will lead to the penalties up to and including exclusion.

However, refusal to sign will not prevent the application of penaltie(s).

IDENTIFICATION AND MARKINGS

The Organizers will supply the following for all vehicles during scrutineering:

- 1) 1 windscreen sticker, a strip 10 cm high.
- 2) 2 rally plates measuring 43x21.5 cm at front and rear, compulsory.
- 3) 2 rally plates with number measuring 50 x 52 cm.
- 4) 2 advertising plates, measuring 50 x 52 cm.

EXAMPLE:

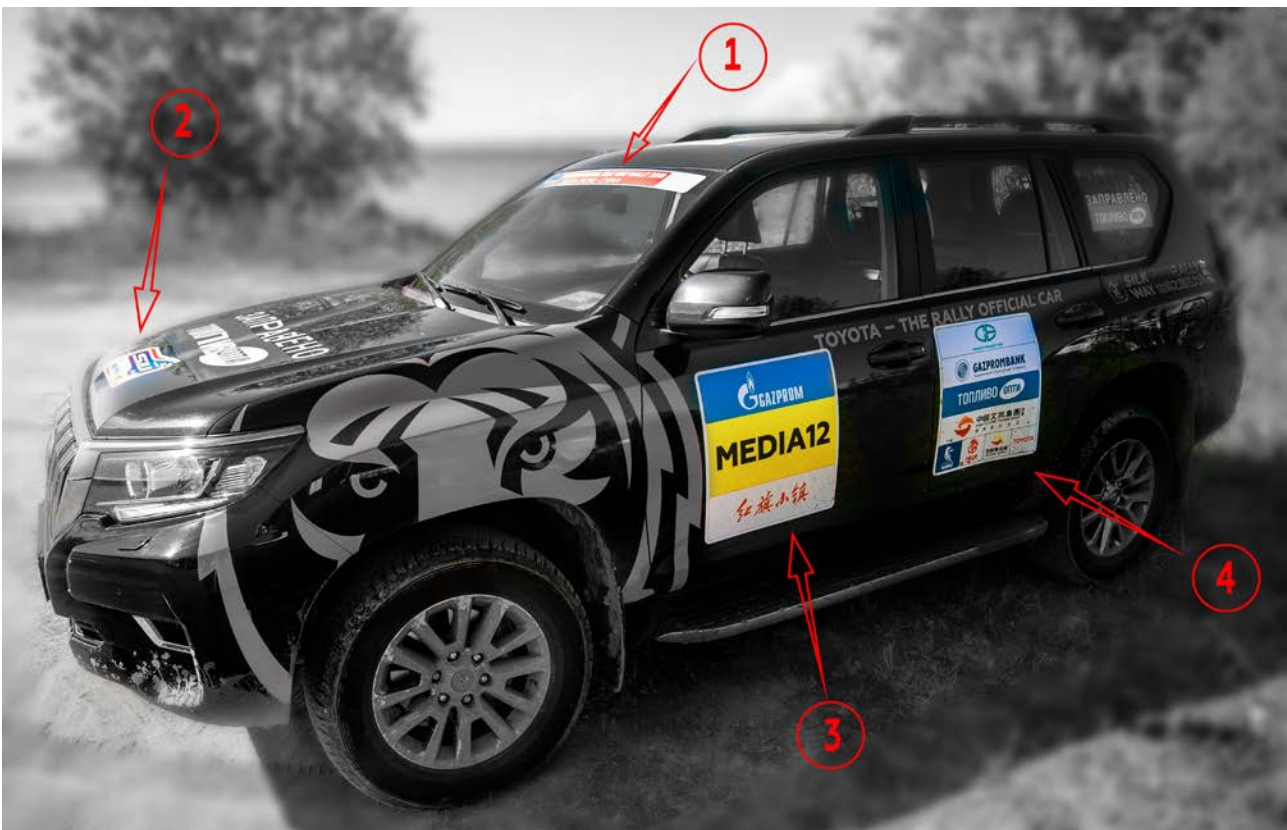



TECHNICAL REGULATIONS FOR PRESS VEHICLES FOLLOWING THE RACE ROUTE

It is **not necessary** for press vehicles to be homologated by the FIA. However, cars must comply with all of the safety standards of the technical regulations for the Production category (T2). These technical regulations may be consulted on the website: www.fia.com, SPORT/Regulations/Rallies/ FIA WORLD CUP FOR CROSS COUNTRY RALLIES.

Standard 4x4 vehicle (petrol or gasoline powered) must comply with the T2 regulations (standard vehicles), even if this car does not have official FIA approval.

The Organizers reserve the right to refuse every vehicle that does not comply with the requirements.

SAFETY EQUIPMENT FOR PRESS CARS FOLLOWING THE RACE ROUTE

Each press vehicle must be presented at scrutineering with the following equipment. If any item is missing, they will not be allowed to start.

- 1 torch,
- 3 hand smoke-generating flares,
- 1 compact mirror,
- 1 compass, 1 lighter,
- 1 foil survival blanket per person,
- 1 first aid kit,
- water tank of 5 litres per person,
- 1 seatbelt cutter per person,
- 1 hazard warning triangle,
- 2 fluorescent waistcoats,
- **1 Iridium satellite (recommended) or GSM telephone**
- **GPS-Sentinel (ERTF) is obligatory** (see Appendix in Supplementary Regulations for Cars and order form on the web site),
- **1 Iritrack** (see order form on the web site),
- 4 points safety seatbelts (minimum),
- hand operated 2 kg extinguisher,
- external rear view mirrors,
- 2 tow hooks (1 at the front, 1 at the back),
- multi-layered windscreen,
- air horn (powerful),
- individual seats,
- rear lighting system complying with the Supplementary Regulations for Cars,
- 2 spare wheels,
- mudflaps,
- 2 ladders and 2 spades,
- 5 m towing strap,
- roll-bars,
- tire jack,
- tire wrench.

Maximum car height (roof rack is included) is 2.50 m, fuel tank sufficient for 800 km: the spare tank(s) for petrol-powered vehicles must be of FT3 type. Diesel fuel tanks must be made and marked by an approved fuel tank manufacturer.

NB: fuel tanks must be filled from outside the vehicle. Pipes, mountings and vents must

conform to the technical regulations for off road vehicles.

ROLL BARS (only for vehicles following the race route)

Roll bars must correspond to FIA standards: diameter - 50 mm minimum; thickness - 2 mm
Material: cold drawn seamless carbon steel. Bolts must be at least size 8 and comply with ISO 8.8 standard norms.

Anchorage points and structures:

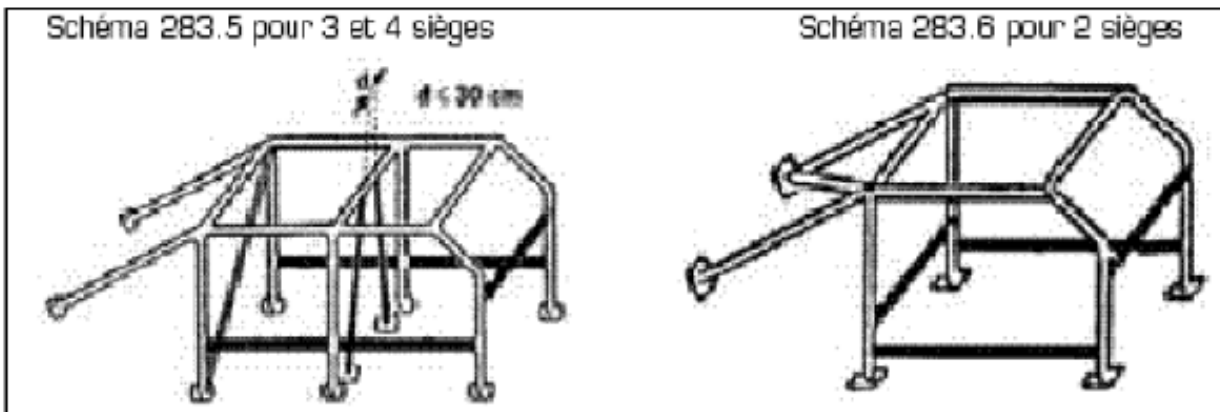

SENTINEL GPS SYSTEM (race route only)

To increase safety when overpassing on the track, the **SENTINEL system with the GPS function** is mandatory for vehicles following the race track. This system warns about overtaking. As soon as you receive the warning signal from a competitor who is behind you (light/sound) you respond to the signal and you move to the side of the track to allow the competitor to pass you.

PERSONAL SAFETY

For your own safety, it is strongly recommended to wear a helmet on the race track; using the safety belts is compulsory throughout the entire route.

SAFETY EQUIPMENT FOR PRESS CARS FOLLOWING THE SERVICE ROUTE

Roll bars are not mandatory.

The following equipment is mandatory:



- 1 pocket torch,
- 1 first aid kit,
- 1 seatbelt cutter per person,
- 1 hazard warning triangle,
- 2 fluorescent waistcoats,
- *satellite phone with a fixed antenna or GSM (optional)*
- **1 smalltrack** (see order form on the web site),
- hand operated 2 kg extinguisher,
- external rear view mirrors,
- air horn (powerful),
- 2 spare wheels,
- tire jack,
- tire wrench,
- 5 m towing strap.

Maximum car height (roof rack is included) is 2.50 m. Diesel fuel tanks must be made and marked by an approved fuel tank manufacturer.

NB: fuel tanks must be filled from outside the vehicle. Pipes, mountings and vents must conform to the technical regulations for off road vehicles.

FUEL

The Organizers do not provide fueling.

TRACK CLOSURE

The «sweeping» vehicles (tow trucks) will close the rally route.

It is impossible to guarantee that the sweeping truck will pass the exact spot where your vehicle has broken down. Therefore, the crew must signal about their presence with the help of radio, satellite telephone or their safety equipment.

The sweeping truck will transport all passengers of broken vehicle and will tow it up to the next asphalt road. **Recuperation of the vehicle is then at the crew's expense.**

Sweeping trucks may ensure the recovery of broken-down or accidented vehicles, only if the latest are located on the itinerary of the road-book. If the sweeping truck cannot reach the position of the broken-down or accidented vehicle, crew will thus be in charge of the recovery of their vehicle on the track. They may get all necessary information to recover their vehicle from the press department.

Crew members who refuse to board the sweeping vehicle do so at their own risk and must sign a discharge that will be presented to them by the Organizers in charge of closing the track. No further recourse may be taken against the Organizers as a consequence of this refusal once the discharge has been signed.



LOSS OF VEHICLE (complete or partial destruction)

1. If a vehicle is damaged (accident, fire, destruction, etc.), the participant must:
 - notify the rally Organizers
 - contact the regional police department to obtain a set of documents for the subsequent provision to insurance company and to the customs post if the press car crosses the border. The documents must contain facts, registration number, racing number, contact details of the people involved, random witnesses, etc. The duplicate must be transferred to the Organizers.
2. The traffic accident participant must contact the Organizers to know what to do. The vehicle must be returned to the start or finish city, where the local authorities will decide, depending on the state of the vehicle, whether it should be re-exported, destroyed, or whether cancellation of its temporary import is justified. Any additional repatriation costs must be paid by the crew.
3. In addition to the risks incurred locally by failure to comply with the rules in force (fines, impoundment of vehicle / passengers, etc.), any crew found to have breached this rule will get a fine of 1.500 €.

RESPECT SENSITIVE AREAS

- a) In agricultural or forest areas, settlements or areas that are fenced for security reasons the itinerary indicated in the road book must be scrupulously followed. In particular, it is forbidden to cut corners, cross fields, forests, orchards or marshes:
 - 1st violation: 1.000 €
 - repeated violation: exclusion
- b) So as to respect the crossed areas, it is forbidden to destroy the fences and gates located along the route. Judges of fact will be on spot. All broken fences will result in a penalty of €1.000. In case a gate, a fence, etc. is destroyed, the crew is liable for all costs incurred. All repeated violations will result in a penalty of €1.000 and up to exclusion.**
- c) It is forbidden to leave punctured or damaged wheels, tires, spare parts on the route. Any crew caught disobeying this rule will be penalized 1.000 € per tire, wheel or part. Repeated violation will result in penalties up to exclusion.**



PRESS ACCREDITATION PLANE/ BUS

5300 €
PER PERSON

Accreditation period: 01-11 July 2021. Entire rally route.

Full payment of the INDIVIDUAL PRESS ACCREDITATION PLANE/ BUS fees must be done right after you receive the confirmation of your accreditation from the Organizers and before 1st June 2021.

Impossible to change names in this accreditation after 1st June 2021.

The press transport is exclusively reserved for permanently accredited journalists and/or photographers of international and nation-wide daily periodicals, media agencies and radio stations.

IMPORTANT: Any accredited person who decides not to use Organizers' transport to travel between bivouacs, must necessarily warn the people in charge of the Press Office 48 hours before (see Contacts).

Beyond two breaches of this rule, the person concerned will be erased from the lists that enable the daily access to transportation means provided by the organizers.

Number of seats is restricted!

The Organizers reserve the right to accept or refuse any request for accreditation.

| This rate includes | This rate does not include |
|----------------------------------------------------------------------------------------------------------------------------------------------------------------------------------------------------------------------------------------------------------------------------------------------------------------------------------------------------------------------------------------------------------------------------------------------------------------------------------------------------------------------------------------------------------------------------------------------------------------------------------------------------------------------|-------------------------------------------------------------------------------------------------------------------------------------------------------------------------------------------------------------------------------------------------------------------------------------------------------------------------------------------------------------------|
| <ul style="list-style-type: none">- PLANE/BUS transfer on the whole rally itinerary from Omsk to City of finish from July 02 to 11 2021- Access to the rally press center on start / finish and on the bivouacs.- Meals at the bivouacs from July 02 to 11 morning (breakfast, ration/lunch, dinner).- Media-guide and other documentation.- Internet connection during the rally (traffic limits are fixed by the organizers).- Insurance and medical repatriation.- Third party liability insurance.- Access to the Prize Giving ceremony- Ambulance repatriation insurance. | <ul style="list-style-type: none">- Flight to Omsk and from Ulaanbaatar - Accommodation at start and at finish- Meals in Omsk and Ulaanbaatar- Travel expenses- Phone calls- Tent and sleeping bag to sleep on the bivouacs.- Visa expenses- Purchase or rental of satellite phone (optional) |



Organizers will accept applications for permanent INDIVIDUAL PRESS ACCREDITATION PLANE/BUS sent online via the official rally website www.silkwayrally.com before **20 May, 2021**. Request for accreditation, sent after this date, will not be accepted.

The organizing committee will confirm the permanent INDIVIDUAL PRESS CAR PACK accreditation before 5 June, 2021.

The administrative checks are obligatory for all journalists with the INDIVIDUAL PRESS ACCREDITATION PLANE/BUS.

The INDIVIDUAL PRESS ACCREDITATION PLANE/BUS request form must be completely filled out on the website and sent to the organizing committee along with the following documents (sent / attached in electronic form):

- Letter from the editor-in-chief of the media, indicating the purpose of the trip, a preliminary plan of the publications about the rally and media output data (circulation (audience), distribution / broadcasting area (see sample in Appendix 2)).
- Letter from the sports team head, if the application comes from the team press officer.
- Copy of a press card (editorial card) of accredited journalists/photographers.
- Obligation to comply with press regulations (see Appendix 1).
- Medical certificate (see the application form on the website www.silkwayrally.ru).
- Color photo 3x4 cm for each crew member. Recent less than 6 months
- Copy (scan) of passport.

Each journalist must present the valid documents mentioned above in their original form at the administrative checks and scrutineering. Any original document missing at administrative checks and/or scrutineering will lead to a refusal of accreditation for the journalist/ photographer. No photocopies or declaration of loss and/or theft will be accepted.

LUGGAGE

It is strictly forbidden to transport in one's luggage spare parts, tools, a competitor's personal belonging under penalty of cancellation of accreditation and exclusion from the rally of the persons concerned (journalist and competitor). The maximum permitted weight is **23 kg per person** (including only 1 bag, the sleeping bag and the tent), **plus hand luggage, but no more than 10 kg with acceptable dimensions for regular flights**.

You will travel on regular flights as well and be submitted to safety checks as in a national airport.



TRANSPORT

In cases when the Organizers will use a bus for delivery to / from the plane, journalists are obliged to use this bus, as they will not always be allowed to get to the airport by themselves. **It should be understood that the Organizers do not guarantee the presence of journalists at all bivouacs, if security conditions require it.**



PRESS ACCREDITATION SERVICE VEHICLE

3200 €
PER PERSON

Accreditation period: 01-11 July 2021. Entire rally route.

Full payment of the PRESS ACCREDITATION SERVICE VEHICLE fees must be done right after you receive the confirmation of your accreditation from the Organizers and before 1st June 2021. Names change in this accreditation is impossible after 1st June 2021.

By the term PRESS ACCREDITATION SERVICE VEHICLE are concerned journalists, sponsor representatives, photographers, teams press officers transported aboard a team vehicle along the assistance route.

Organizers reserve the right to accept or refuse any request for accreditation.

This rate includes

- Catering at the bivouacs from 02 to 11 July morning (breakfast, packed lunch, dinner).
- Media-guide and other documentation.
- Access to the rally press center at the start / finish and at the bivouacs.
- Data transmission from the media center at the start, finish and from the bivouacs, Internet connection in the press center at the start and finish (traffic limits are fixed by the Organizers).
- Participation in the Prize Giving ceremony.
- Ambulance repatriation insurance.

This rate does not include

- Flight to Omsk and from Ulaanbaatar - Accommodation and meals in the cities of start and finish of the rally.
- Visa expenses.
- Phone calls.
- Fuel
- Tent, sleeping bag and other bivouac equipment.

Organizers will accept applications for permanent PRESS ACCREDITATION SERVICE VEHICLE sent online via the official rally website www.silkwayrally.com before **01 June, 2021**. After this date, it will no longer be possible to make a request for accreditation.

The obligatory administrative checks for all journalists with the PRESS ACCREDITATION SERVICE VEHICLE will be held according to the rally schedule and program.



The PRESS ACCREDITATION SERVICE VEHICLE request form must be completely filled out on the website and sent to the organizing committee along with the following documents (sent / attached in electronic form):

- Letter from the sports team head with the indication of vehicle that journalist will use during the rally.
- Letter from the editor-in-chief of the media, if the journalist represents it, indicating the purpose of the trip, a preliminary plan of the publications about the rally and media output data (circulation (audience), distribution / broadcasting area (see sample in Appendix 2)).
- Obligation to comply with press regulations (see Appendix 1).
- Medical certificate (see the application form on the website www.silkwayrally.ru).
- Color photo 3x4 cm for each crew member. Recent less than 6 months
- Copy (scan) of passport.

Each journalist must present the valid documents mentioned above in their original form at the administrative checks and scrutineering. Any original document missing at administrative checks and/or scrutineering will lead to a refusal of accreditation for the journalist. No photocopies or declaration of loss and/or theft will be accepted.

ASSISTANCE/SERVICE TO A COMPETITOR

A person having a press accreditation is not allowed to help the race competitors in whatever manner!

IT IS PROHIBITED:

- to transport spare parts,
- to transport bivouac equipment,
- to help with technical problems, etc.

If such is the case, this person could be expelled from the rally and lead to withdrawal from the race of the concerned competitor.

**PRESS ACCREDITATION HOSTED
MEDIA****FREE.
COMPETITIVE
basis**

Accreditation period: 01-11 July 2021. Entire rally route.

The rally Organizers bear all the costs of a field work of a journalist. Applications from editors/journalists/bloggers are accepted from 15 April to 14 May, 2021. **Requests for the HOSTED MEDIA ACCREDITATION made after this date will not be considered.**

Names change in this accreditation is impossible after 1st June 2021.

Applications for permanent HOSTED MEDIA ACCREDITATION are accepted by the Organizing committee of the race until 14 May, 2021.

This ACCREDITATION request form (see **APPENDIX 3 FOR A SAMPLE REQUES**) must be completely filled out and sent to the organizing committee along with the following documents (sent / attached in electronic form) to accreditation@silkwayrally.ru:

- Request form - Letter from the editor-in-chief of the media, if the journalist represents it, indicating the purpose of the trip, a preliminary plan of the publications about the rally and media output data (circulation (audience), distribution / broadcasting area (see sample in Appendix 3).
- Obligation to comply with press regulations (see Appendix 1).
- Medical certificate (see the application form on the website)
- Color photo 3x4 cm for each crew member. Recent less than 6 months
- Copy (scan) of passport.

The choice of media wishing to participate is on a competitive basis. The decision will be made in the period from 15 to 20 May by the tender committee consisting of the rally media director, marketing director, heads of media services of the European, Russian and Chinese departments.

The Organizing committee reserves the right to satisfy or refuse any request for accreditation. The decision of the tender committee will be published in the Media section of the official rally website on 20 May, 2021, media/journalist/blogger notified by e-mail. A media that has been denied this type of accreditation may apply for other types of accreditations specified in these regulations.

Media partner can attach any documents and / or information to the application.



The rally Organizing committee takes on the following expenses and provides:

- Flight to start city and flight back from finish city
- Vehicle (car space or movement by plane / bus) along the rally route, depending on the media plan of the journalist
- Accommodation at the race start and finish (hotels), as well as along the rally route
- Catering in the cities of start and finish
- Catering at bivouacs from 2 to 10 July (breakfast, packed lunch, dinner) and breakfast on 11 July
- Visa expenses
- Press guide and other racing documentation
- Data transmission from the media center at the start, finish and from the bivouacs, Internet connection in the press center at the start and finish
- invitation to the Prize Giving ceremony
- Ambulance repatriation insurance

The media editorial office undertakes to:

- provide accurate information about the media and the journalist covering the rally
- send a journalist of the media to the international 2021 Silk Way Rally
- publish announcements about the Silk Way Rally on the media site and carry out the rally coverage in accordance with the media plan, specified in the application for accreditation

After receiving confirmation and decision of the tender committee, the media editorial office fills out the accreditation request form in accordance with the Organizers recommendations on the website using the link sent and attaches the following documents:

- o Copy of a press card (editorial card) of accredited journalists/photographers/camera men.
- o Obligation to comply with press regulations (see Appendix 1).
- o Medical certificate (see the application form on the website www.silkwayrally.ru).
- o Color photo 3x4 cm for each crew member.
- o Copy (scan) of passport of every journalist.

An accredited media journalist is guided by the press regulations during the rally route.



FREE

DAILY PRESS ACCREDITATION

Accreditation period: three days during the 2021 Silk Way Rally.

Accreditation entry forms will be available at www.silkwayrally.com after 15th of June 2021

The application period: start from 15th of June, 2021.

End of application: two days before the visit to the chosen bivouac/start/finish.

The number of daily accreditations is limited per media and cannot exceed:

- **For TV channels – not more than 5 persons**
- **For Radio, printed media, internet – not more than 2 persons.**

Request for daily accreditation at start and/or finish and/or bivouac along the rally itinerary should be accompanied by the letter from the editor-in-chief of the media, indicating a preliminary plan of the publications about the rally and media output data. To receive the accreditation at the start and at the finish it is necessary to present the copy of press card and/or editorial card.

Accreditation provides a daily access to:

- Bivouacs (without food)
- Spaces for competitors
- Press information in the electronic form (dedicated area, no access to the Media Center)
- Podiums (dedicated area)
- **Catering is not included in a DAILY ACCREDITATION.**
- **The exit to the racing track is prohibited.**
- **The media representative bears the communication expenses.**
- **The Organizers do not provide transport, computers, and other office equipment, as well as the Internet connection.**

CAUTION: It's impossible to obtain daily accreditations for more than **3 rally legs**.

The rally leg is:

- Administrative checks and start podium.
- Any entire leg, starting from the morning and finishing at night.
- Final leg and finish podium.



FINAL PROVISIONS

The Press Regulations, as well as all its Appendices, are developed in accordance with the FIA recommendations, the Law of the Russian Federation dated 12.27.1991 No. 2124-1 (as amended on 01.03.2020) "On the Media", the Federal Law dated 04.12.2007 No. 329-FZ (as amended on 02.08.2019) "On Physical Culture and Sport in the Russian Federation", Decree of the Government of the Russian Federation of 13 September, 1994 No. 1055 "On Approving the Rules for the Accreditation and Stay of Foreign Media Correspondents in the Russian Federation".

CONTACTS

Press-center SWR

Common questions

Lina Arnautova
E-mail: lina.arnautova@silkwayrally.ru
Tel: +7 921 9390149

Daily Accreditation

Olga Eremeeva
accreditation@silkwayrally.ru

International

Chris Rodrigo
E-mail: crodrigo@silkwayrally.ru
Tel: +33(0)607226233

Belen Otero

E-mail: belen@silkwayrally.ru

China

Kathy Li Hui
E-mail: kathylihui@126.com
Tel: +86 137 1870 5302

TV Accreditation

Eric Khayrullin
E-mail: media@silkwayrally.ru

ERTF

(Race GPS + Sentinel)
Cathy Tournaire
E-mail: competition@ertf.com
Tel: +33 (0) 2 97 87 25 85
Parc Technologique de Soye
56 275 Ploemeur - France

MARLINK EVENTS SAS – RALLY RAID DEPARTMENT

(Iritrack & Satellite Phone)
Mehdi Couillard
E-mail: mehdi.couillard@marlink.com
Tel: +33 (0)1 48 84 34 07
114 / 126, avenue d'Alfortville
94600 Choisy le Roi - FRANCE
Tel: +33 (0)1 48 84 34 00
Fax: +33 (0)1 48 52 53 54

TRIPY SA

(Service GPS)
E-mail: silkwayrally@tripy.be
Tel: + 32 (0)71 34 74 90
Fax: + 32 (0)71 34 73 99
Faubourg de Bruxelles, 320
Gosselies 6041 - Belgium



SILK WAY 2021 RALLY 丝绸之路拉力赛



APPENDICES

- Appendix 1: Rules of conduct and obligation of the journalist
- Appendix 2. Sample letter of the editor-in-chief
- Appendix 3: Sample application for hosted media accreditation
- Appendix 4: Technical requirements for videos sent from the media center
- Appendix 5: Limited image license. rules of usage for images and videos



APPENDIX 1: RULES OF CONDUCT AND OBLIGATION OF THE JOURNALIST

Within the framework of the chosen accreditation, I confirm that I agree with processing of my personal data collected during registration by the Organizer of the Silk Way Rally; and I also agree to the transfer of my personal data upon request to services and companies that host the race and help with it.

I also undertake to:

- comply with safety rules and with the requirements of rally officials, security marshals, line judges and those involved in ensuring rally safety.
- choose the points indicated for the press for shooting, avoiding the presence in dangerous and forbidden corners, being guided by the following safety schemes, including, but not limited to:



- Always keep a sports car in sight
- Not to stand with my back to the rally track
- Not to sit near the track; be able to move urgently
- Not to stand outside the corners
- Not to stand below the level of the road, at the foot of the dunes being out of sight of the race participants
- Not to stand in prohibited areas
- Expect unexpected: a car due to a malfunction may start moving NOT along the visible rally track
- Not to cross the rally track



Dangerous area. Avoid being in these sectors on the rally track!

I am aware of the degree of danger that may be associated with the fulfillment of my professional journalist duties at this competition.

I acknowledge that, being in the territory of the rally countries, I fall under the jurisdiction of the host country laws.

As the rally participant, I undertake to ensure that my actions, videos and publications **do not include** advertising / promotion / propaganda of the following:

- alcohol,
- tobacco,
- pharmaceuticals,
- religion,
- politics,
- pornography.



SILK WAY 2021 RALLY

丝绸之路拉力赛



TRADEMARKS

The Silk Way trademark and white tiger logo are the exclusive property of the Rally Organizer – the Silk Way Rally Motorsport Support and Development Association. The use of the Silk Way name and logo is strictly limited to use by the Organizer, Partners of the event and authorized licensees. The use of the Silk Way logo for commercial purposes is strictly prohibited. Changing the Silk Way logo is strictly prohibited.

RIGHT TO A SPORTS EVENT COVERAGE

The Organizers and Partners of the sports events own the rights to their coverage by broadcasting the image and (or) the sound of the events by any means and (or) using any technology, as well as by recording the specified broadcast and (or) shooting the events.

The rights to cover the Silk Way international rally may be used by third parties only on the basis of the permission of the Organizers or written agreements on the acquisition of these rights from the Organizers of such events by third parties.

An accredited person, regardless of the type of accreditation, is obliged to send to accreditation@silkwayrally.ru the report on the Silk Way International Rally coverage that should contain: the date, time and duration of each broadcast at the request of the rally Organizers; and also to provide the organizers free of charge in case of their special request part of the video materials (photo, video) in electronic format or any other convenient way.

I, the undersigned

Full name _____

Date of birth _____

Address: _____

accredited by the 2021 Silk Way Rally Organizers, claim:

I confirm that I am familiar with the “Press Regulations” and undertake to comply with them and the rules of conduct at the rally.

Handwritten signature and comment: “I have read and agree. I bear responsibility for my life and health”.

Date _____



SILK 2021 RALLY WAY 丝绸之路拉力赛



APPENDIX 2. SAMPLE LETTER OF THE EDITOR-IN-CHIEF

COMPANY FORM

To the Silk Way Rally Organizers

I ask you to accredit **full name, position** (journalist / photographer / cameraman / personal correspondent) from **“the media name”** to work at the 2021 Silk Way International Rally. I confirm and provide the following information:

Media name: _____

Media type: TV / Radio / Internet media / Printed media / Weblog

Coverage/circulation: _____ a month _____ a year

Region: _____

Publications are planned in a section: (specify address, name of section) _____

Footage is planned in: specify TV/radio programs

Website: _____

Media plan of publications on the Silk Way Rally subject

| No. | Date | Platform | Type of publications / nature | Estimated coverage / footage time |
|------------|-------------|-------------------------|--------------------------------------|------------------------------------------|
| 1 | 03/07/2021 | Media name/ URL address | Ceremonial start review | 20.000- 50.000 views |
| 2 | 03/07/2021 | Facebook.com/name | Ceremonial start image gallery | 50-70.000 people |
| 3 | 04/07/2021 | “Program name” | Footage in the “program name” | 2.5 minutes |

Editor-in-chief of “media name”:

Signature:

Date:



SILK WAY RALLY 2021 丝绸之路拉力赛



APPENDIX 3: SAMPLE APPLICATION FOR HOSTED MEDIA ACCREDITATION

COMPANY FORM _____

To the Silk Way Rally Organizers

Please consider the application from «Media Name/Journalist/Blogger» to participate in the rally SILK WAY RALLY 2021 for informational coverage of the race.

I confirm and provide the following information:

Media name: _____

Journalists _____ name(s) _____

Number of journalists: _____

Media type: TV / Radio / Internet media / Printed media / Weblog

Coverage/circulation: _____ a month _____ a year

Region: _____

Publications are planned in a section: (specify address, name of section) _____

Footage is planned in: specify TV/radio programs

Website: _____

Media plan of publications on the Silk Way Rally subject (EXAMPLE)

| No. | Date | Platform | Type of publications / nature | Estimated coverage/ footage time |
|------------|-------------|-------------------------|--------------------------------------|-----------------------------------------|
| 1 | 03/07/2021 | Media name/ URL address | Ceremonial start review | 20.000- 50.000 views |
| 2 | 03/07/2021 | Facebook.com/name | Ceremonial start image gallery | 50-70.000 people |
| 3 | 04/07/2021 | “Program name” | Footage in the “program name” | 2.5 minutes |

Editor-in-chief of “media name”:
Date

Signature



SILK 2021 RALLY WAY 丝绸之路拉力赛



APPENDIX 4: TECHNICAL REQUIREMENTS FOR VIDEOS SENT FROM THE MEDIA CENTER

- Format: mp4
- Codec: h264
- Resolution: 568 x 320 or 480 x 272
- Number of frames per second: 25
- Quality: full
- Video bitrate: 1500 Kbps
- Audio: MPEG AAC Audio (mp4a),
- Frequency: 44100 Hz
- Audio codec: mp3 or AAC – stereo
- Audio bitrate: 96 kbps

Based on these parameters, a three-minute video will "weigh" about 20-30 Mb.

TECHNICAL REQUIREMENTS FOR YOUR LAPTOP

Please see below for technical requirements for your computer if you need to be connected to the race network. Please note: we will modify the configuration of your laptop in order to connect you to the local network. If your system is protected by a user name or password, please contact your administrator who will provide you with a user name and "administrator" password.

Your computer must meet the following requirements:

- PC**
- Minimum processor: 32bits or 64 bits 1Ghz
 - RAM: min. 1Go (32bits) or 2Go (64bits)
 - Disk Space: 40Go
 - Network card: 100/1000 RJ45, 2.4 Ghz Wi-Fi b/g/n or 5 Ghz an/ac
 - Operating system: Win7/Win8/Win10, Linux or higher
 - Browser up-to-date: IE11, Firefox, Chrome, Edge, others.

Administrator's rights

- APPLE**
- Type: MacBook / MacBook Pro
 - RAM: min 2Gb
 - Disk space: 40Gb
 - Network card: 100/1000 RJ45, 2.4 Ghz Wi-Fi b/g/n or 5 Ghz an/ac
 - Operating system: OS X
 - Browser up-to-date: Safari, Firefox, Chrome

Administrator's rights

Your system must be protected by up-to-date antivirus software. You are advised to purchase a cable lock for your computer.



SILK WAY 2021 RALLY

丝绸之路拉力赛



APPENDIX 5: LIMITED IMAGE LICENSE. RULES OF USAGE FOR IMAGES AND VIDEOS

INDEX:

1. SWR (Silk Way Rally) official images with open license available during the rally
- 1.2. Conditions to broadcast SWR images on TV
2. SWR official video contents available during the rally (digital media use)
- 2.1 и 2.2. Conditions to use SWR official video contents (digital media)
3. Conditions to send images from the SWR media center

1. SWR (SILK WAY RALLY) OFFICIAL IMAGES WITH OPEN LICENSE AVAILABLE FOR TV DURING THE RALLY.

- 3-minute daily videos for news access;
- videos available on FTP and DROPBOX using the link given in the permission;
- route maps, official graphics set, logos.

1.2 CONDITIONS AND RULES REGARDING THE USE OF SILK WAY RALLY OFFICIAL IMAGES:

1.2.1 SWR non-rights-holders (broadcasters without any agreement with SWR wishing to broadcast dedicated programs from the 2021 SWR) are entitled to broadcast, on a linear basis, a maximum of 1 (one) minute race footage per event day to be incorporated solely within:

- Regular TV news channels, sport news bulletins, magazines, sports magazines, not dedicated to the SWR.

SWR non-rights-holders and the accredited channels in the frameworks of “daily accreditation” for the Silk Way Rally are entitled to broadcast behind the scenes’ footage (bivouacs, interviews) made by their own means in the programs described above. The global linear basis broadcast should not exceed 2 (two) minutes (1’ of race footage + 1 behind the scenes’ footage).

- **Pay your attention that the channel or the SWR non-rights-holder after their broadcast should send a broadcast report including: date, time and length of each broadcast to tv@silkwayrally.ru as well as by the Organizers request provide free of charge part of footage (photo, video) in soft copy or in any other convenient way to the Organizers.**

1.2.2 SWR non-rights-holders are not authorized to use any SWR pictures for commercial or sponsorship purpose.

- It is strictly forbidden for non-rights-holders or TV channels to stream videos of the SWR by means of Internet and/or mobile distribution technologies except as follows:
- The streaming is part of the simultaneous broadcast of the TV channel without any changes on the channel own edited generic website.
- The streaming is part of VOD catch-up service of the entire regularly scheduled news bulletins and/or sport news bulletins, but not the designated magazines, on the TV channel generic internet and mobile platforms.



SILK 2021 RALLY WAY 丝绸之路拉力赛





SILK 2021 RALLY WAY 丝绸之路拉力赛



2.1 DIGITAL PLATFORMS ENTITLED TO BROADCAST/HOST SWR OFFICIAL VIDEOS:

Only the following categories of digital platforms/media are entitled to use SWR official videos:

- Pure player digital news portals, online newspapers, radio, and digital media related to general or specialized news, sports and motorsport news solely for its own operated website / mobile application / social networks.
- *It is expressly agreed that no TV channel website / mobile app shall have access to SWR official video contents.*
- Official SWR partners and racing teams are allowed to host/broadcast SWR official videos on their own operated websites / mobile applications / social networks without any changes.

IMPORTANT: The Organizers and Partners of the sports events own the rights to their coverage by broadcasting/hosting any other content with SWR images by any means and (or) using any technology, as well as by recording the specified broadcast and (or) shooting the events.

For any broadcast/hosting of any other content with SWR race images, a specific agreement with the Organizers is required. It is possible to request the permission for license acquisition from the TV production group head.

2.2 LICENSE CONDITIONS:

The use/hosting/broadcasting of the here above contents (official videos) are subject to the respect of the following license conditions:

Access to free videos through embedded code:

- Only TV channels holding SWR rights may host/broadcast the official SWR videos on their websites and/or mobile applications.
- Embedded code is available on the official SWR YouTube channel in the Share button settings of every video.
- Pre-roll & post-roll advertising prior the start and after the end of the video: a maximum of 4 sec.
- It is strictly forbidden to edit/modify the SWR official videos.

IMPORTANT: In no case shall a third party brand that is not an official sponsor of the event, be associated neither with the SWR brand nor with its official videos or prevail from any form of sponsoring with the SWR.

VIDEOS PROVIDED BY THE SPECIAL AGREEMENT:

FOR TV CHANNELS, 12-minute daily videos are available. Videos are available via FTP link SWR and are provided upon agreement. The request is made to the media department / TV production department.

PLATFORMS/SITES FOR HOSTING:

- The video usage shall be limited only to the operated website and mobile application for every media and / or this website is owned and / or edited by accredited media.



- Official rally videos may be broadcasted / hosted exclusively on their own websites or mobile applications of the media / sponsors / teams indicated in the accreditation. It is forbidden to download and

post / distribute official race videos on platforms and social networks where there is an embed code like YouTube, RuTube, Daily Motion, in own media / team / rally accounts.

- A website and a mobile application that host official videos should not be created for the race, be dedicated to it or specialize only in SWR.
- Access to official materials should be free, posted videos on the platform of the media / partner / team should not be available for download to the end user. It is not allowed to inform third parties about the source of access (direct links) to videos outside the website / application, where the video is posted.

3. CONDITIONS TO SEND IMAGES FROM THE SWR BIVOUACS:

Accreditation of camera crews is subject to prior agreement with the SWR. Detailed information can be obtained from the Press Regulations.

- Accredited camera crews or TV broadcasters are allowed to transmit footages from the media center if they have permission (license) from the SWR Media service that will give them advice on the terms and conditions of transmissions (International, Russian or Chinese contact according to the country where images are distributed).

Pay your attention that the accredited camera crews or TV broadcasters by the Organizers request should provide free of charge part of footage in soft copy or in any other convenient way to the Organizers.

Accredited media within the framework of the **DAILY ACCREDITATION** package must obtain permission from the SWR Media Center to transmit videos / images; the media must contact the media director in advance (International, Russia or China) and provide the following information:

- Image/video format,
- Estimated file size and volume (preliminary)
- Website(s) (name, description and URL link), application... where the materials will ultimately be posted.

The Organizers will review and process each request.

Pay your attention that the accredited camera crews or TV broadcasters by the Organizers request should provide free of charge part of footage in soft copy or in any other convenient way to the Organizers.